

**Yotta Sport RAID Subsystem  
Hardware Installation Guide  
Ver. 1.0**

## **Copyright ©2006**

This guide and any accompanying software and firmware are copyrighted. No parts of this publication may be reproduced, stored on a retrieval system, or transmitted, in any form or by any means, electronic, mechanical, photocopy, recording, or otherwise, without prior written consent except for copies retained by the purchaser for backup purposes.

All rights Reserved- Printed in Taiwan.

## **Notice**

We make no warranties with respect to this documentation either express or implied and provide it "as it". This includes but is not limited to any implied warranties of merchantability and fitness for a particular purpose. The information in this document is subject to change without notice. We assume no responsibility for any errors that may appear in this document.

The manufacturer shall not be liable for any damage, or for the loss of information resulting from the performance or use of the information contained herein

## **Trademarks**

Product names used herein are for identification purposes only and may be the trademarks of their respective companies. All trademarks or registered trademarks are properties of their respective owners.

## Regulatory information

### For Europe

This drive is in conformity with the EMC directive.

### Federal Communications Commission (FCC)

#### Statement

This equipment has been tested and found to comply with the limits for a Class A digital device, pursuant to part 15 of the FCC Rules.

Those limits are designed to provide reasonable protection against harmful interference in a residential installation. This equipment generates, uses and can radiate radio frequency energy and, if not installed and used in accordance with the instructions, may cause harmful interference to radio communications. However, there is no guarantee that interference will not occur in a particular installation. If this equipment does cause harmful interference to radio or television reception, which can be determined by turning the equipment off and on, the user is encouraged to try to correct the interference by one or more of the following measures:

Reorient or relocate the receiving antennas.

Increase the separation between the equipment and receiver.

Connect the equipment into an outlet on a circuit different from that to which the receiver is connected.

Consult the dealer or an experienced radio/TV technician for help.

#### Warning:

A shielded-type power cord is required in order to meet FCC emission limits and also to prevent interference to the nearby radio and television reception. It is essential that only the supplied power cord be used.

Use only shielded cables to connect I/O devices to this equipment.

You are cautioned that changes or modifications not expressly approved by the party responsible for compliance could void your authority to operate the equipment.

## About This Hardware Installation Guide

Welcome to Hardware Installation Guide. This guide is designed to be used as step-by-step instructions for installation of your subsystem, and covers everything you need to know in learning how to operation, troubleshooting and future upgrades. For the detail about how to configure your subsystem, please refer to the Software Operation manual.

## Symbols in Text

These symbols may be found in the text of this guide. They have the following meanings.

---

---

### Caution

---

---

*This icons indicates that failure to follow directions could result in personal injury, damage to your equipment or loss of information.*

---

---

---

---

### Note

---

---

*This icon presents commentary, sidelights, or interesting points of information. .*

---

---

Important terms, commands and programs are put in **Boldface** font.

Screen text is given in **screen** font.

## Contents

ABOUT THIS HARDWARE INSTALLATION GUIDE.....	IV
SYMBOLS IN TEXT.....	IV
CONTENTS.....	V
<b>CHAPTER 1. INTRODUCTION .....</b>	<b>1</b>
MODEL VARIATIONS.....	1
FEATURES .....	1
UNDERSTANDING THE YOTTA SPORT RAID SUBSYSTEM.....	3
<i>Rear Panel Overview</i> .....	5
<b>CHAPTER 2. INSTALLATION.....</b>	<b>7</b>
UNPACKING & CHECKING THE EQUIPMENT.....	7
WHAT ELSE YOU NEED .....	8
ESD PRECAUTION.....	8
INSTALLING HARD DISKS .....	8
INSTALL THE YOTTA SPORT RAID SUBSYSTEM IN A RACK .....	10
SYSTEM CONNECTION.....	14
<b>CHAPTER 3. TROUBLE SHOOTING .....</b>	<b>15</b>
REPLACE THE CONTROLLER.....	15
REPLACING / UPGRADING DIMM.....	16
<i>Specifications:</i> .....	16
<i>Architecture of supported DIMM:</i> .....	17
<i>Installing DIMM</i> .....	17
HOT SWAPPING TO REPLACE THE FAN MODULE.....	18
HOT SWAPPING TO REPLACE THE POWER MODULE.....	19
<b>APPENDIX A .....</b>	<b>21</b>
<b>CONNECTORS .....</b>	<b>21</b>
<b>APPENDIX B.....</b>	<b>24</b>
<b>BATTERY BACKUP MODULE (BBM) .....</b>	<b>24</b>
<i>BBM Components</i> .....	24
<i>BBM Specifications</i> .....	25
<i>Installation</i> .....	25
<i>Battery Backup Capacity</i> .....	25

<i>Operation</i> .....	26
<i>Removing the Battery Backup Module</i> .....	26
<b>APPENDIX C. SPECIFICATIONS</b> .....	<b>27</b>
SPECIFICATIONS.....	27

# Chapter 1. INTRODUCTION

This chapter introduces the features and capabilities of Yotta Sport RAID subsystems.

## You will find:

- ⇒ A full introduction to your Yotta Sport RAID subsystem.
- ⇒ Details of key features and supplied accessories.

## Model Variations

There are two available models in Yotta Sport RAID storage subsystem series, one of two utilize Ultra320 SCSI as Host interface, The other model supports 4Gb FC via SFP connector.

<i>Model Name</i>	<i>Host Interface</i>	<i>Device bays</i>
YI-16SA2U4	4x Ultra320 SCSI	16 bays
YI-16SA2F4	4x 4Gbps FC	16 bays

## Notice:

- ⇒ YI-16SA2U4/F4 are integrated with dual independent raid controllers. Each of raid controller only manage 8 xSATAII drives. Two raid controllers can manage 16 x SATAII totally.
- ⇒ Please configure the YI-16SA2U4/F4 via two networking ports, both of networking ports are with different IP.

## Features

The Yotta Sport series is a high performance, external RAID subsystem using new generation of Serial ATA 2.0 channels for disk drives and either Ultra320 SCSI or 4Gbps Fibre channel I/O standard to connect services to Host computer.

Target usage ranges are set from small business to departmental and corporate server needs. The Yotta Sport RAID is designed for easy integration, smooth data expansion and server migration.

When properly configured, the Yotta Sport RAID can provide non-stop service with a high degree of fault tolerance through the use of RAID technology and advanced array management features.

The Yotta Sport series supports the following features:

- High performance super scalar Intel Xscale 80321 IO processor.
- Superior Array Management Firmware supports RAID levels 0, 1 (0+1), 3, 5, 6 and JBOD RAID configurations.
- Advanced 100MHz/64-bit PCI-X bus architecture
- Cache memory utilizes the Fastest 64-bit 200Mhz ECC DDR SDRAM and cache memory size up to 1 gigabytes.
- Quad Ultra-320 SCSI Host Interconnect supported
- Quad Loop of 4Gb/sec Fibre Channel via SFP connector
- New generation Serial ATA 2.0 Drive Interface supported,
- Dual independent raid controller , each of controller supports 8 x SATAII.
- Redundant and Hot Swappable Fan, Power and Drives.
- Hot Swap, Hot Spare and Automatic Drive Rebuild Supported.
- Configuration and environmental information is accessible either via the control panel or Serial Port or 10/100 Ethernet LAN port.
- E-mail event notification.
- Load sharing hot swappable redundant power system with PFC function.
- Host System independent.
- Operating System independent.

## Understanding the Yotta Sport RAID subsystem

### Front Panel Overview

#### LCD Module( Front side )

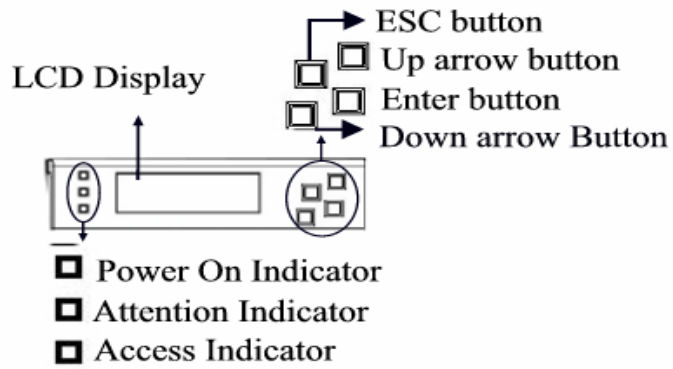

#### LCD Module (Back side)

There is a switch on the back side of LCD module.

*The LCD displays messages for raid controller 1 when the switch is set at upper place .*

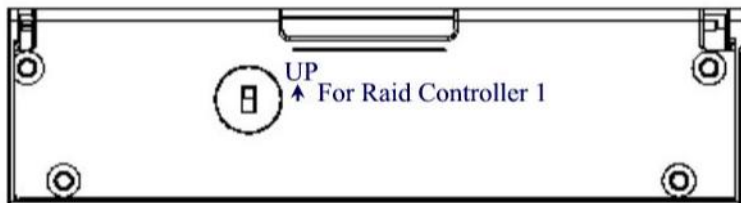

The LCD displays messages for raid controller2 when the switch is set at lower place .

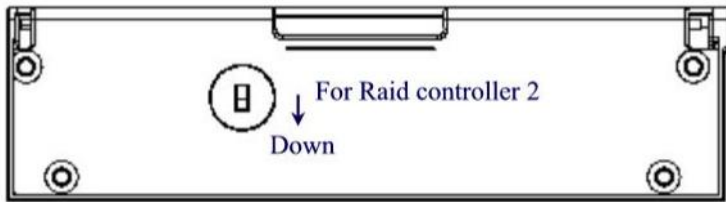

### Driver Bay numbering convention

The enclosure bay numbering convention is shown in following figure. A bay is designed to house a single 1.0-inch high, 3,5-inch hard disk drive in his carrier module.

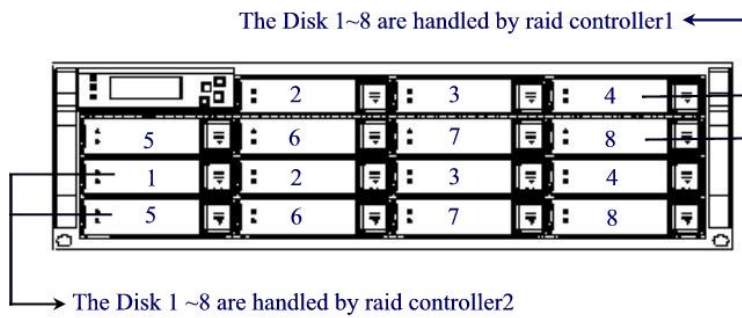

The YI-16SA2U4/F4 has two independent raid controllers , the raid controller 1 handles the upper 8 HDDs , the raid controller 2 handles the lower 8 HDDs.

## Drive Bay

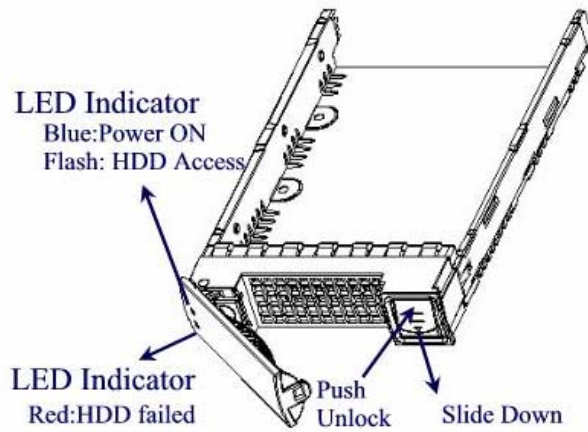

## Rear Panel Overview

YI-16SA2U4

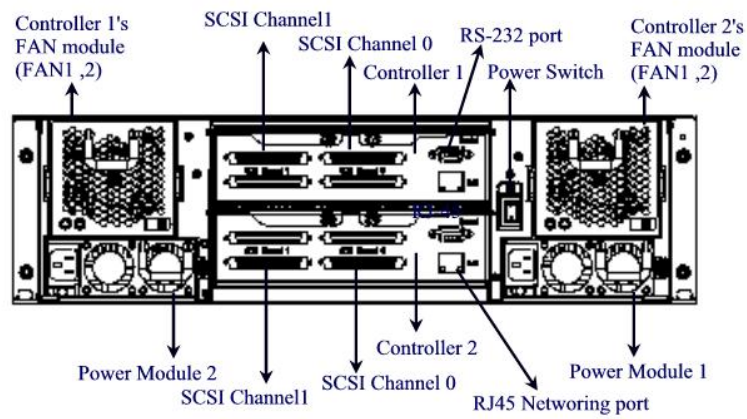

YI-16SA2F4

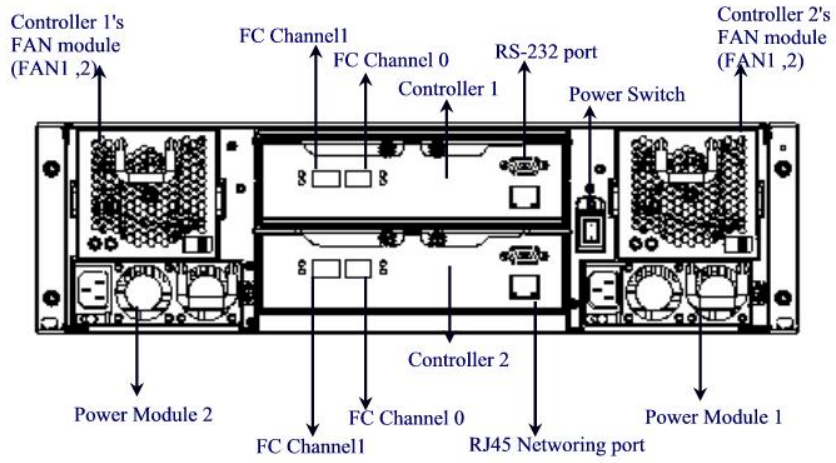

---

## Chapter 2. INSTALLATION

---

**This chapter presents:**

- ⇒ **Instructions on unpacking & checking the equipment**
- ⇒ **Instructions on how to install Hard disk drive**
- ⇒ **Instructions on how to install Yotta Sport RAID in a Rack.**
- ⇒ **Instructions on how to connect Yotta Sport RAID.**

### Unpacking & checking the Equipment

Before unpacking the Yotta Sport RAID subsystem, prepare a clean, stable surface to put on the contents of Yotta Sport RAID shipping container. Altogether, you should find following items in the package :

#### Yotta Sport SCSI to SATA II Subsystem

- Yotta Sport RAID subsystem x1
- CD-ROM x 1 ( Includes Hardware Installation Guide, Software operation Manual & HTTP Proxy Server utility for Web browser-based Configuration).
- Ultra320 SCSI Cable x2
- Null cable x1
- Ultra320 SCSI Active Terminator x2
- Power Cord x 2
- Spare Fan x 1
- Spare Drive Bay x 1
- Rails for Rack
- Mounting screws (bag) x1

#### Yotta Sport Fibre to SATAII Subsystem

- Yotta Sport RAID subsystem x1
- CD-ROM x 1 ( Includes Hardware Installation Guide, Software operation Manual & HTTP Proxy Server utility for Web browser-based

Configuration).

- Null cable x1
- Power Cord x 2
- Spare Fan x 1
- Spare Drive Bay x 1
- Rails for Rack
- Mounting screws (bag) x1

---

### Note

---

*To avoid the unmatched connector type between the Fibre HBA in the Host computer and Yotta Sport RAID, The RAID system doesn't include the Fibre cable with the standard shipping.*

---

## What else you need

- Hard disk drives (different RAID levels requires different numbers of HDDs. Refer to Software Operation manual for more detail information.
- Host computer with SCSI or Fibre interface.
- Dedicated terminal or PC with third party communication software that supports ANSI terminal emulation (required for viewing Monitor Utility)

## ESD Precaution

Use a suitable anti-static wrist or ankle strap and observe all conventional ESD precaution when handle Yotta Sport RAID's modules and components. Avoid contact with backplane components and module connectors.

## Installing hard disks

The Yotta Sport RAID supports 16 hot swappable drive bays. The following sections describe how to install disks into Yotta Sport RAID subsystems.

### Remove the empty hot swappable driver bays

1. Push the unlock button then slide down the Releaser on drive bays .
2. Left the handle to disengage the drive bay from the slot.

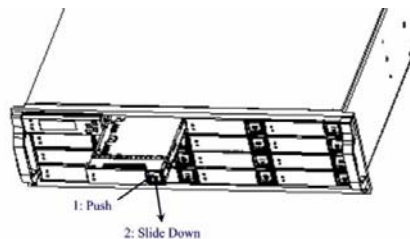

**Loading Hard Disk to the drive bay.**

1. Put HDD into the bay.
2. Fasten all 4 screws to mount HDD in the bay and make sure the HDD is properly tightened.

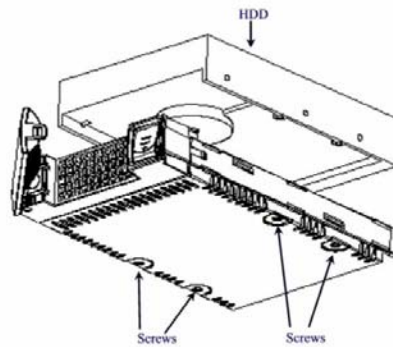

**Place drive bays back into the system**

1. Slide in drive bay, make sure the handle is open fully.
2. Close the handle to engage the drive bay into the slot.

---

---

**Note**

*The hard drives in a RAID array should match in size and speed. All drives in any array should be identical models with the same firmware versions. RAID arrays can use any size drive, however the smallest drive will determine the size of the array.*

---

---

**Caution**

*Only use the screws offered with Yotta Sport RAID subsystem. Longer screws might cause the drive damage.*

---

---

**Caution**

*All the drive bays ( with or without hard drive) must be placed in the Yotta subsystem. Yotta's cooling system is designed with full of drive bays. Missing drive bays might cause the subsystem damage.*

---

---

## Install The Yotta Sport RAID subsystem in a Rack

You are shipped one rackmounting kit for each Yotta Sport RAID subsystem that you intend to rackmount. Yotta Sport RAID subsystem is designed for installation into a industry-standard 19-inch rackmount cabinet. Following the use of this section for installing the Yotta Sport RAID subsystem into a Rack

### Step1: Assemble and adjust the slide Rails

- a. Insert rear slide rail into left (right) slide rail
- b. Adjust the length of the slide rails
- c. Install P4\*8M Screw and M4 NUT as **figure 1**
- d. Determine where in the rack, the subsystem is going to be.  
Install the brackets in the rack. Secure each side of the brackets with two position screws through the front rack posts, and two position screws through the rear rack posts.  
When the rails can be properly fitted to the rack posts, fasten the screws.

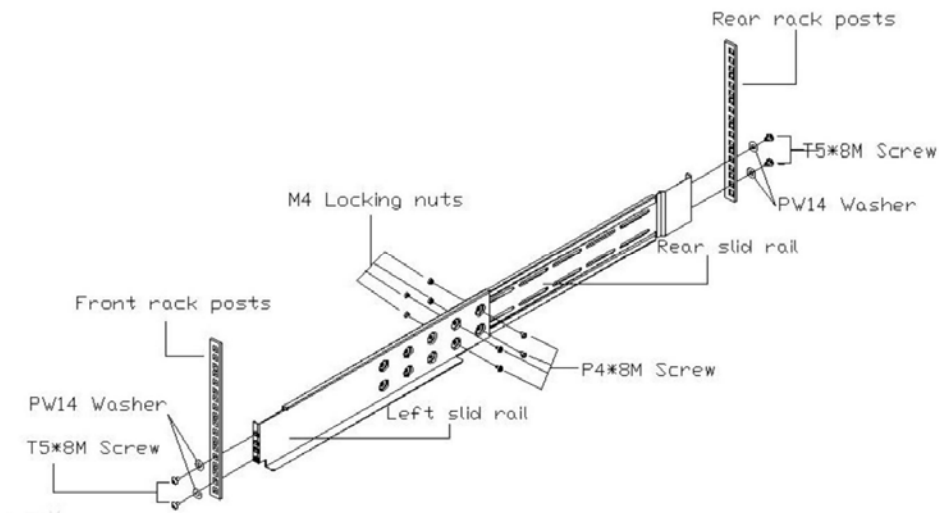

**Figure 1: Assembly Slid rail and rack posts**

### Step 2 : Install Clip nuts

Attach M5 clip nut on each side of the front rack posts.  
clip nuts use the figure 2 below to locate the clip nuts.

Note:

These clip nuts will be used to secure the subsystem through its front ears  
as will be discussed in Step 4.

---

---

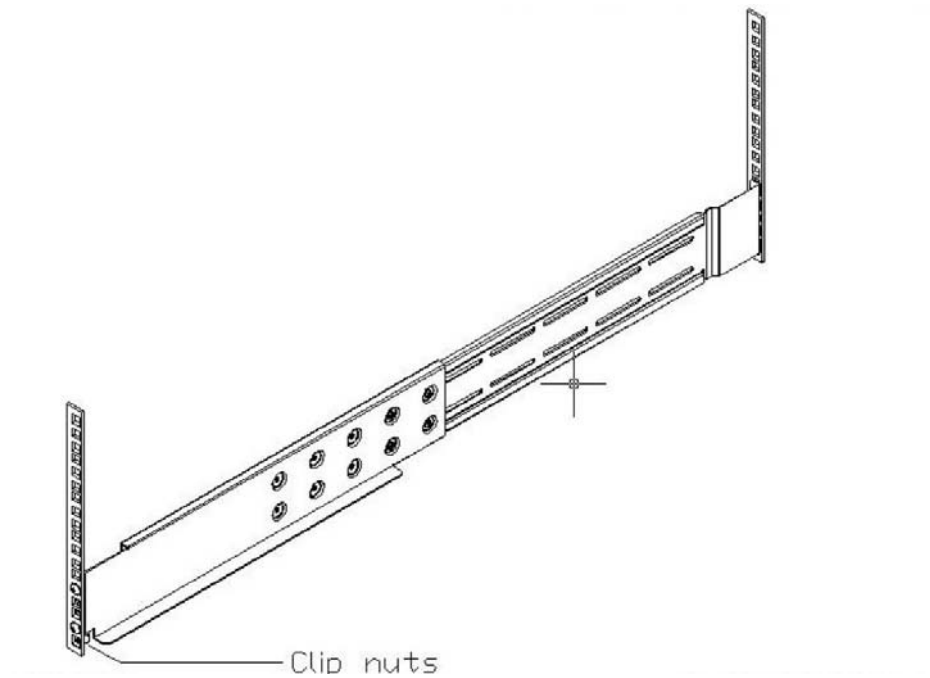

Figure 2: Attach the clip nuts to the rack posts

### Step 3 : Slide the subsystem into the server rack

Lift the subsystem enclosure and slide it slowly and gently along the slide rail into the rack.

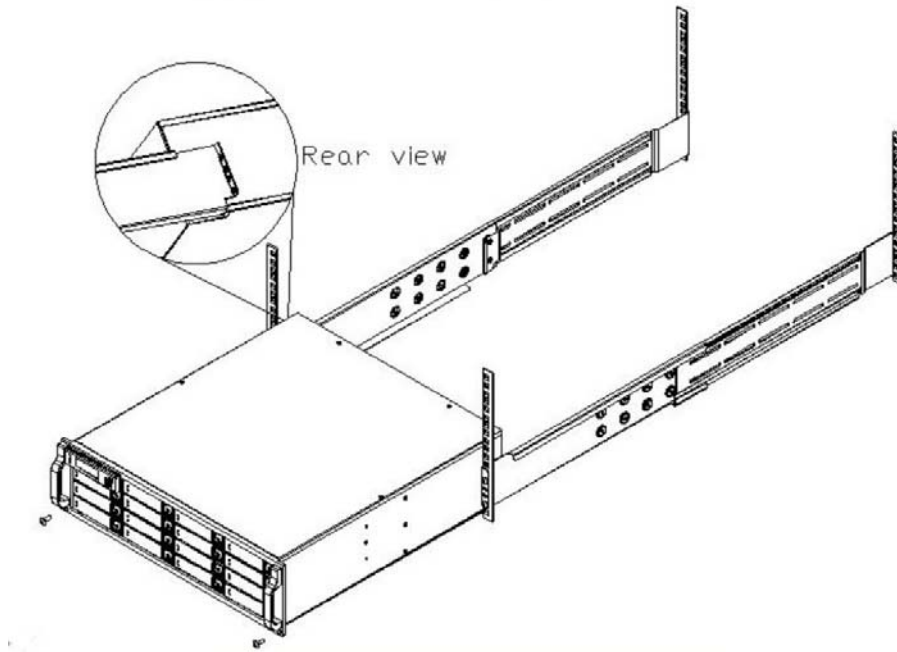
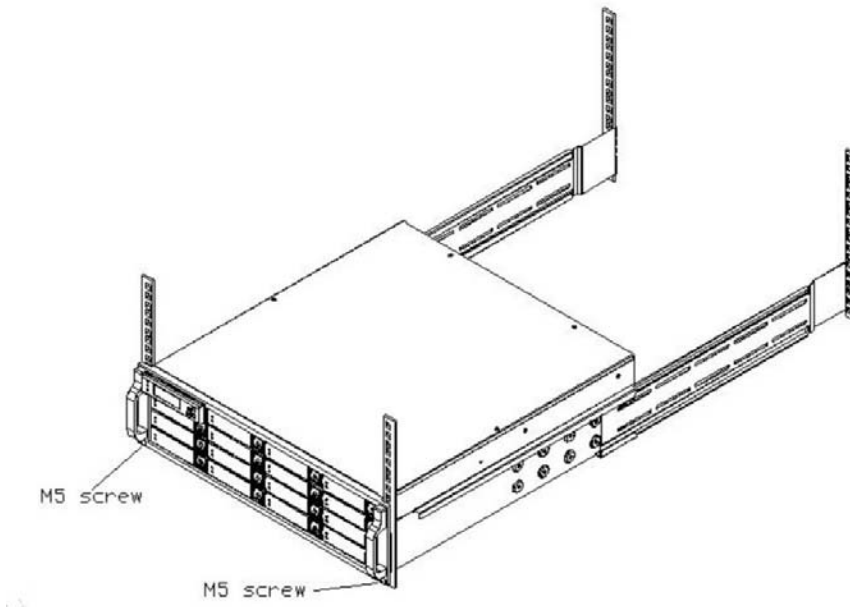

Figure 3: Slide the subsystem into the server rack

**Step 4 : Secure the subsystem in the server rack**

Fasten two M5 screws through the chassis ears in the front side of the chassis. The RAID subsystem should now be securely mounted into the rack.



**Figure 4: Secure the subsystem in the server rack**

**Install the Yotta Sport RAID subsystem into the Rack Cabinet**

1. Lift the Yotta Sport RAID subsystem ( one person on each side of the Yotta Sport RAID) and approach the rack with the button-back of the Yotta Sport RAID subsystem facing the end of Slide rails.
2. Slide the Yotta Sport RAID subsystem evenly into the rack cabinet all the way.
3. Using the rackmount screws , secure the top and bottom of the Yotta Sport RAID subsystem to the rack frame.

---

**Caution**

*The Yotta Sport RAID subsystem is heavy, two person are required to move the system in the procedure.*

---

## System Connection

Connect all cables and power cord as shown below :

Cable	Yotta Sport RAID	Device	Purpose
Null Cable	RS-232 Port	ANSI Terminal or a PC with Terminal emulator.	Configuration Utility
SCSI cable / Fibre cable	Primary SCSI/ FC-AL Secondly SCSI/ FC-AL	HBA of Host computer	Host interface between RAID and Host computer
Power Cord	Power inlet	A/C power outlet	A/C power input
RJ 45 Cable	Ethernet Port	Switch or HUB	Connect to Internet .

---

### Note

---

*Yotta Sport RAID subsystem do not require the installation of different drivers for use with different operating systems. Yotta Sport RAID is independent and transparent to the host operating system.*

---

## Chapter 3. TROUBLE SHOOTING

**This chapter contains trouble shooting procedures and suggestions to minimize their impact on the Yotta Sport RAID operation :**

⇒ **Instructions on how to replace the components of Yotta Sport RAID subsystem.**

If the fault LED on the front panel and LCD of Yotta Sport RAID lights red and LCD displays a error message , or if Yotta Sport RAID's Internet manager indicates a fault, determine the reason for this alert immediately. Examine the component LEDs to see if any indicates a fault, then replace it as soon as possible.

### Replace the Controller

#### Caution

*Read the replacing notices earlier in this chapter before proceeding with replacement.*

This section provides instructions for the removal and installation of the RAID controller components indicated in the figure below. This section is for the reference of engineers. End users should not need to replace or remove components.

#### Removing the controller from Yotta Sport RAID :

In order to access controller box, turn anti-clock wise to release two thumb screws on eject bar, then use the eject bar to remove the controller box.

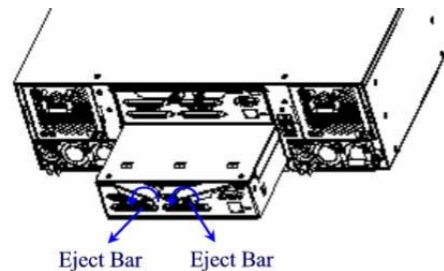

Disconnect all cables, then unscrew four fasteners on controller and upward to remove it.

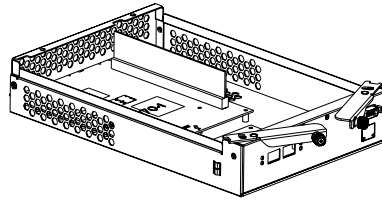

### Installing the controller into Yotta Sport RAID:

Reverse the procedure of “**removing the controller**” to install the controller into Yotta Sport RAID.

Then according to “Appendix C. Configuration table” on “Soft Operation Manual” to reconfigure your RAID

## Replacing / Upgrading DIMM

---

---

### Note

---

---

*There's no set formula to determine how much cache memory to use, but as a general rule, a workstation, with mostly very large files, such as for audio or video editing and playback, graphics or CAD files, can benefit from a large cache. File servers, with multiple random access of varying file size, generally have little or no performance improvement with additional cache.*

---

---

### Specifications:

Type	◆ 184-pin DDR DIMM module (DDR-266) ◆ ECC, without Register and Unbuffered.
Parity (ECC)	◆ With parity for data security.
Size	◆ From 64MB, 128MB, 256MB, 512MB to 1GB

---

---

**Architecture of supported DIMM:**

Size	Architecture
64 MB	◆ 9 (8M bit x 8)
128 MB	◆ 9 (16M bit x8)
256 MB	◆ 9 (32M bit x 8) ◆ 18(16M bit x8)
512 MB	◆ 9 (64M bit x 8) ◆ 18 (32M bit x 8)
1 GB	◆ 9 (128M bit x 8) ◆ 18 (64M bit x 8)

**Note**

*If you have plan to install a Battery Back up module with Yotta Sport RAID subsystem, we will strongly recommend you to choice the memory module which uses the low power consumption memory chips. Only this type of memory can meet the spec. of maximum memory back up duration. Especially, for memory sizes are 512MB and 1GB.*

**Installing DIMM**

To install a DIMM, ensure the system power is off and disconnected. Then:

1. Turn anti- lock wise to release three thumb screws, then use the eject bar to remove controller box.
2. Remove the daughter board.
3. Insert a memory card at a 45-degree angle into the memory card socket so that the gold teeth of the card are no longer visible.
4. Press the card down firmly until the latches lock it into place.

**Caution**

*Before starting any kind of hardware installation, please ensure that all power switches have been turned off and all power cords disconnected to prevent personal injury and damage to the hardware*

**Caution**

*Use screws provided with Yotta Sport system only. Longer or shorter screws may cause electric shorting or un-proper installed.*

**Caution**

*Static electricity can damage electronic components. To guard against such damage:*

*Work in a static-free environment*

*Wear a grounded anti-static wrist strap*

*Store uninstalled components in anti-static bags*

*Handle PCBs by their edges and avoid touching chips and connectors.*

## Hot Swapping to replace the Fan Module

This section provides instructions for the removal and installation of the Fan Module indicated in the figure below.

### Removing the Fan Module from Yotta Sport :

Remove the Fan modules by slide the release button left and pull the module out of system.

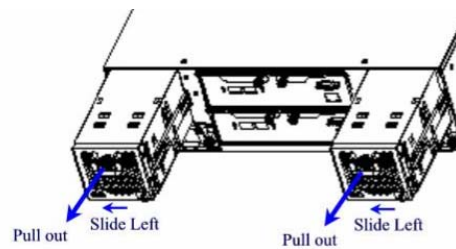

### **Installing the Fan module into Yotta Sport :**

Insert a Fan module.

#### **Replace the Fan in Fan module**

1. There are two failure LEDs on the rear of Fan module. Check which LED lights to yellow.
2. Remove the Fan modules by anti-clock wise to release the thumb screw then slide it back and lifting off.
3. Release the screw to remove the defect fan.
4. Insert the spare Fan and fasten the screw.

## **Hot Swapping to replace the Power Module**

This section provides instructions for the removal and installation of the Power Module indicated in the figure below.

### **Removing the Power Module from Yotta Sport Raid:**

Unscrew the fastener, then push right the release button, slide it back and lifting off.

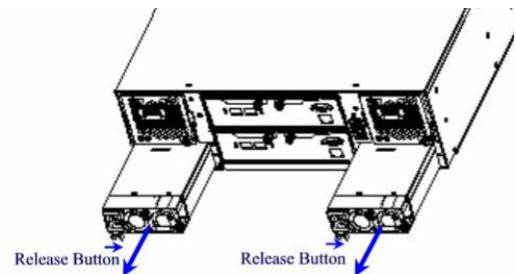

### **Installing the Power module into Yotta Sport:**

Insert a Power module then fasten the screw.

**Note**

*The Power indicator will turn bright "Green" to indicate it has powered on*

# Appendix A

## Connectors

### SCSI Connector

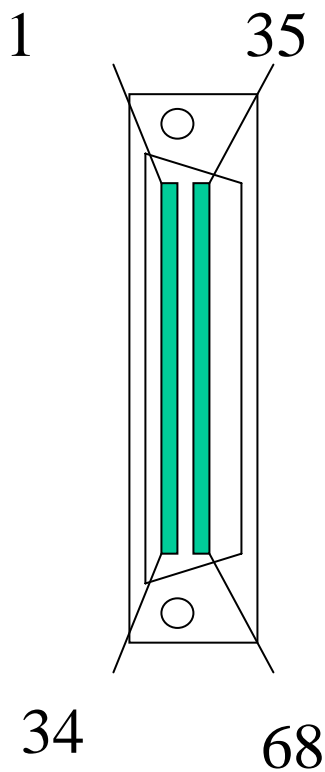

Pin#	Signal Name	Pin#	Signal Name
1	SCSI_AC_DAT<12>+	35	SCSI_AC_DAT<12>-
2	SCSI_AC_DAT<13>+	36	SCSI_AC_DAT<13>-
3	SCSI_AC_DAT<14>+	37	SCSI_AC_DAT<14>-
4	SCSI_AC_DAT<15>+	38	SCSI_AC_DAT<15>-
5	SCSI_AC_PAR<1>+	39	SCSI_AC_PAR<1>-
6	SCSI_AC_DAT<0>+	40	SCSI_AC_DAT<0>-
7	SCSI_AC_DAT<1>+	41	SCSI_AC_DAT<1>-
8	SCSI_AC_DAT<2>+	42	SCSI_AC_DAT<2>-
9	SCSI_AC_DAT<3>+	43	SCSI_AC_DAT<3>-
10	SCSI_AC_DAT<4>+	44	SCSI_AC_DAT<4>-
11	SCSI_AC_DAT<5>+	45	SCSI_AC_DAT<5>-
12	SCSI_AC_DAT<6>+	46	SCSI_AC_DAT<6>-
13	SCSI_AC_DAT<7>+	47	SCSI_AC_DAT<7>-
14	SCSI_AC_PAR<0>+	48	SCSI_AC_PAR<0>-
15	GND	49	GND
16	GND	50	GND
17	TERMPWRA	51	TERMPWRA
18	TERMPWRA	52	TERMPWRA
19	GND	53	GND
20	GND	54	GND
21	SCSI_AC_ATN_L+	55	SCSI_AC_ATN_L-
22	GND	56	GND
23	SCSI_AC_BSY_L+	57	SCSI_AC_BSY_L-
24	SCSI_AC_ACK_L+	58	SCSI_AC_ACK_L-
25	SCSI_AC_RST_L+	59	SCSI_AC_RST_L-
26	SCSI_AC_MSG_L+	60	SCSI_AC_MSG_L-
27	SCSI_AC_SEL_L+	61	SCSI_AC_SEL_L-
28	SCSI_AC_CD_L+	62	SCSI_AC_CD_L-
29	SCSI_AC_REQ_L+	63	SCSI_AC_REQ_L-
30	SCSI_AC_IO_L+	64	SCSI_AC_IO_L-
31	SCSI_AC_DAT<0>+	65	SCSI_AC_DAT<0>-
32	SCSI_AC_DAT<9>+	66	SCSI_AC_DAT<9>-

33	SCSI_AC_DAT<10>+	67	SCSI_AC_DAT<10>-
34	SCSI_AC_DAT<11>+	68	SCSI_AC_DAT<11>-

### Ethernet RJ-45 Connector

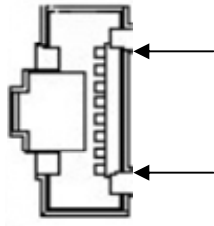

Pin#	Signal Name
1	TX+
2	TX-
3	RX+
4	NC
5	NC
6	RX-
7	NC
8	NC

### Fibre SFP

Pin#	Signal Name
1	VEFT
2	TFAULT
3	TDIS
4	MOD_DEF(2)
5	MOD_DEF(1)
6	MOD_DEF(0)
7	Rate Select
8	LOS
9	VEER
10	VEER
11	VEER
12	RD-
13	RD+
14	VEER
15	VCCR
16	VCCT
17	VEET
18	TD+
19	TD-
20	VEET

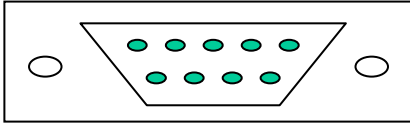
**RS-232 & Modem Male Connector**

Pin#	Signal	Pin#	Signal
1	DCD	6	DSR
2	RXD	7	RTS
3	TXD	8	CTS
4	DTR	9	TXC
5	GND		

## Appendix B

### Battery Backup Module (BBM)

The external RAID controller operates using cache memory. The battery Backup Module is an add-on module that provides power to the external RAID controller cache memory in the event of a power failure. The Battery Backup Module monitors the write back cache on the external RAID controller, and provides power to the cache memory if it contains data not yet written to the hard drives when power failure occurs.

#### BBM Components

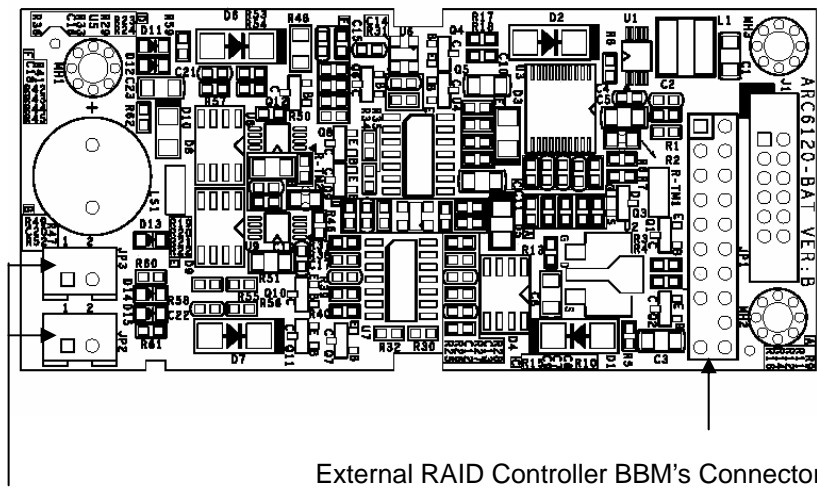

Battery Connector

External RAID Controller BBM's Connector

## BBM Specifications

### Mechanical

Module Dimension (W x H x D) : 148 x 128 x 244 mm

### BBM Connector

2 \* 10 box header

### Input Voltage

+3.6VDC

### On Board Battery Capacity

2000MAH (2\*1000MAH)

### Installation

- Make sure all power to the system is disconnected.
- Connector J5 is available for the optional battery backup module. Connect the BBU cable to the 12-pin battery connector on the controller
- Integrators may provide pre-drilled holes in their cabinet for securing the BBM using its three mounting positions.

### Battery Backup Capacity

Battery backup capacity is defined as the maximum duration of a power failure for which data in the cache memory can be maintained by the battery. The BBM's backup capacity varied with the memory chips that installed on the external RAID controller..

Capacity	Memory Type	Battery Backup duration (Hours)
128MB DDR	Normal (27mA)	74
128MB DDR	Low Power (18mA)	111

## **Operation**

- Battery conditioning is automatic. There are no manual procedures for battery conditioning or preconditioning to be performed by the user.
- Battery had a tendency to “remember” its capacity. In order to make sure of all the capacity of your battery cells, allow the battery cell to be fully charged when installed for the first time. The first time charge of battery cells takes about 24 hours to complete.

## **Removing the Battery Backup Module**

The battery module will need to be removed for one of the following reason:

- Disconnect battery module if there is a long storage period before deployment
- The LI-ION battery will no longer accept a charge properly.

## Appendix C. Specifications

### *Specifications*

<b>RAID Architecture</b>	
Intel Xscale 80321 I/O processor	
Proprietary ASIC to support extreme performance RAID 6 function.	
Up to 1GB 200MHz DDR SDRAM on one DIMM socket with ECC protection	
Marvell 8 channels SATA II controller	
<b>RAID Features</b>	
RAID Levels : 0, 1, 3, 5, 0+1, 6 & JBOD	
Multiple RAID selection	
Online RAID level/stripe size migration	
Online Array roaming	
Online capacity expansion and RAID level migration simultaneously	
Instant availability and background initialization	
Automatic drive insertion / removal detection and rebuilding	
<b>Host Interface</b>	
YI-16SA2U4	YI-16SA2F4
Four Ultra320 SCSI Channels - 320MB/sec per channel	Four 4Gbps Fibre Channels – 400MB/sec per channel
<b>Drive Interface</b>	
16 SATA II channel -3.0 Gbps	
<b>Monitors/Indicators</b>	
LCD Control Panel for setup, alarm mute and configuration	
System status indication through LCD, LED and alarm buzzer	
All system events can be sent to multiple user alerts to be via ' Plain English' e-mails.	
<b>RAID Management</b>	
Field-upgradeable firmware in flash ROM.	

Firmware-embedded manager via RS-232 port.	
Firmware-embedded SMTP manager – Monitor all system events and user can select either single or multiple user alerts to be sent via ' Plain English' e-mails.	
Firmware-embedded Web Browser-based RAID manager via 10/100 Ethernet port	
<b>Operating System</b>	
OS independent and transparent.	
<b>Environmental /Physical</b>	
<b>Cooling System</b>	Hot swappable and redundant Cooling Fan modules.
<b>Power System</b>	Redundant by Dual 460W Power modules with PFC feature, Load Sharing type and cableless design.
<b>Electrical</b>	AC Voltage 110-230 VAC Ac Frequency 50-60Hz
<b>Temperature</b>	Operating Temperature : 10 to 35 degree C.
<b>Relative Humidity</b>	20% to 80% non-condensing
<b>Dimensions</b>	132mm (H) x 447mm(W) x 498mm (D)
<b>Weight</b>	

---

**Note**

---

*Specifications subject to change without notice.*

---